

CrossOver X25 Lock Installation

Need another copy of these installation sheets? You can download one at www.CrossOverLock.com/SupportCenter.htm

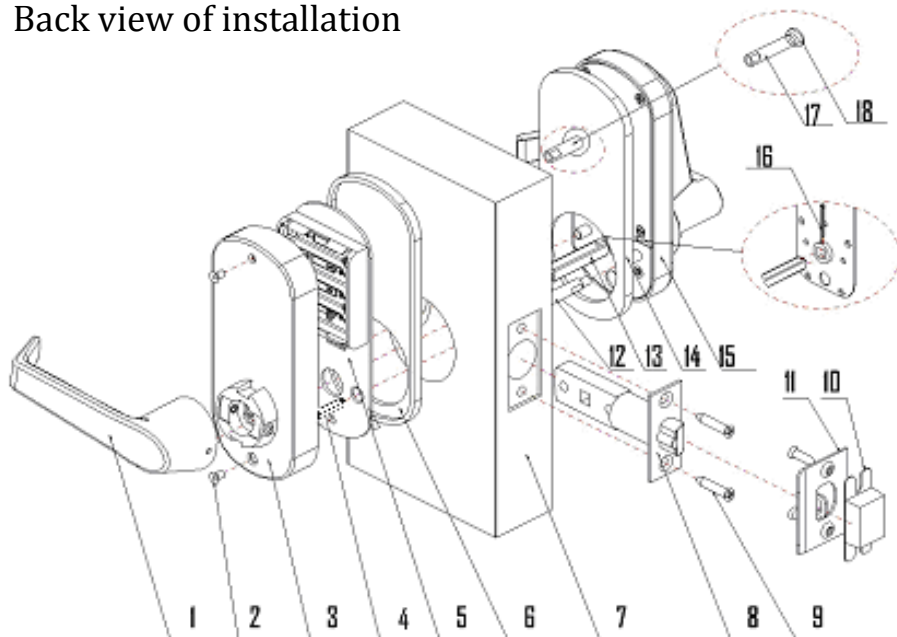











Back view of installation



Major lock parts

- | | |
|-----------------------------|------------------------------------|
| 1. Rear handle | 12. Front lock fastener post |
| 2. Rear lock housing screws | 13. Square drive shaft |
| 3. Rear housing | 14. Front rubber gasket |
| 4. Battery plate screw | 15. Front lock housing |
| 5. Battery plate | 16. Cotter pin |
| 6. Rear rubber gasket | 17. Upper fastener post (optional) |
| 7. Door | 18. Attachment screw (optional) |
| 8. Door | 19. iButton reader |
| 9. Latch screws | 20. Keypad |
| 10. Dust boot | 21. SC4 cylinder |
| 11. Strike plate | 22. Front handle |

Miscellaneous parts

-  Battery Plate Screw (3)
-  Back Cover Screw (2)
-  Screws (4)
-  Square Drive Shaft (1)
-  Cotter Pin (1)
-  Fastener Extension (2)
-  Upper Fastener Extension (1)
-  Latch (1)
-  Strike Plate (1)
-  Dust Boot (1)
-  Mechanical Key (2)
-  SC4 Cylinder (1)

Front view of installation

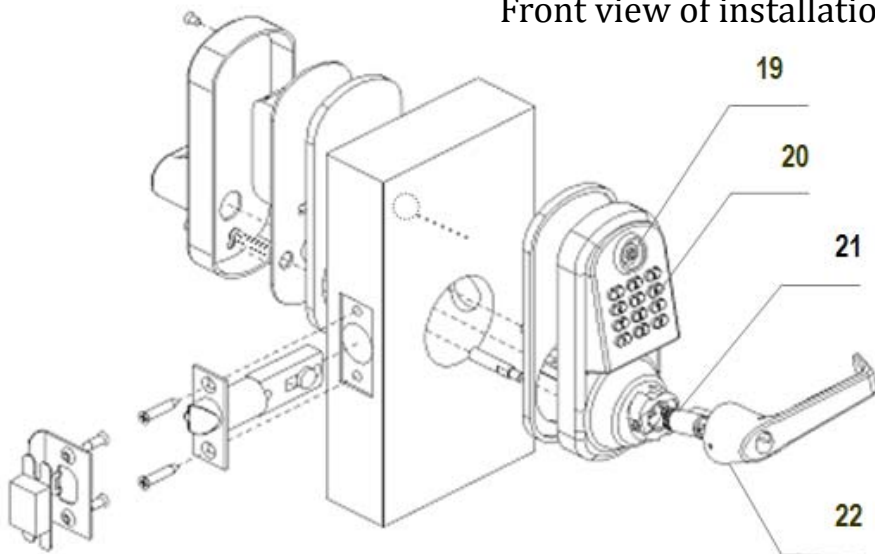

We recommend that the lock be in the unlocked position when you install it. To do so, the position pin with the dot on the housing must be pointing up (see Step 2).

Step 1

If necessary, drill holes in door as shown in the accompanying template. Then insert the latch into the hole and attach it with two screws.

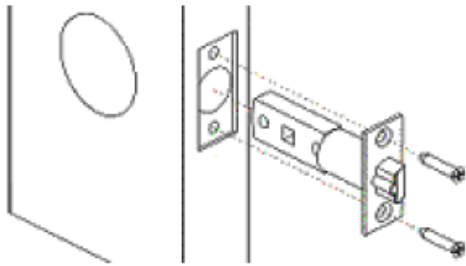

Figure 1

Step 2

Insert the square drive shaft into the front lock housing, ensuring that the small holes on the shaft and the lock housing are vertical. Then slide the cotter pin through the small holes in the housing and through the shaft. Bend the cotter pin around the cylinder as shown in Figure 2A to lock the bar in place.

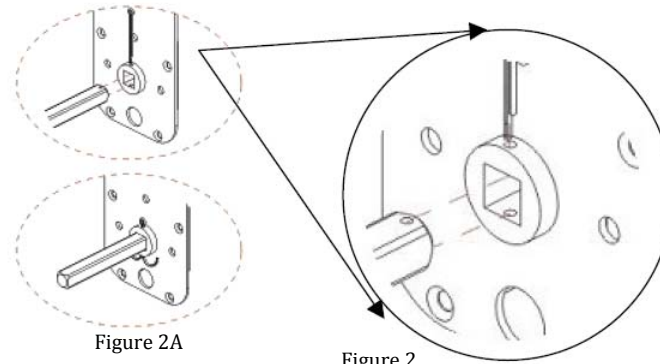

Figure 2A

Figure 2

Step 3

Screw the two lower fastener posts into either side of the back of the front of the lock. The upper fastener post is optional but provides greater stability. To use the upper fastener, insert the brass screw into the fastener and slide it into the slot on the back of the lock as shown below.

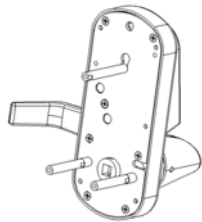

Figure 3

Step 4

Place the front lock housing on the outside of the door, with the front rubber gasket (note the X-shaped slice in the gasket for the optional upper fastener post) between the door and the housing. Feed the power cable through the door hole over the latch.

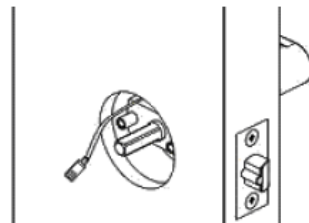

Figure 4

Step 5

Insert the power cable you pulled in Step 4 through the rectangular hole in the battery plate. Attach the plate to the inside of the door with the square drive shaft going through the big hole in the latch, the lower fastener posts through the small holes in the latch and (if you're using it) the optional upper fastener post through the 3/8-inch hole you drilled in the door. Then fasten the plate to the front of the lock with two battery plate screws (three if you used the optional upper fastener post). Plug the power cable into the circuit board directly under the batteries.

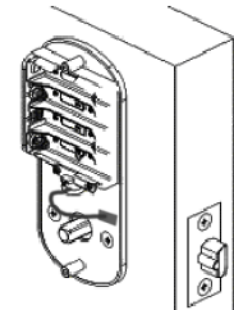

Figure 5

Step 6

Install the batteries, then put the back lock housing over the battery plate. Fasten with 2 screws. Press both catch pins in and snap the rear handle onto the drive shaft.

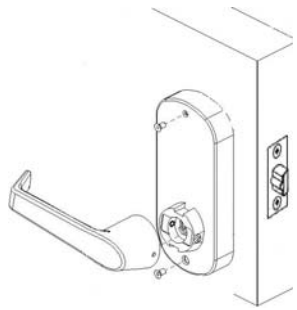

Figure 6

Step 7

Place the lock cylinder into the front handle housing and insert the mechanical key through the hole into the cylinder. Turn the mechanical key 90° (a quarter turn) clockwise. Press both catch pins in and snap the front handle onto the drive shaft. Turn the mechanical key 90° (a quarter turn) counter-clockwise and pull the key out.

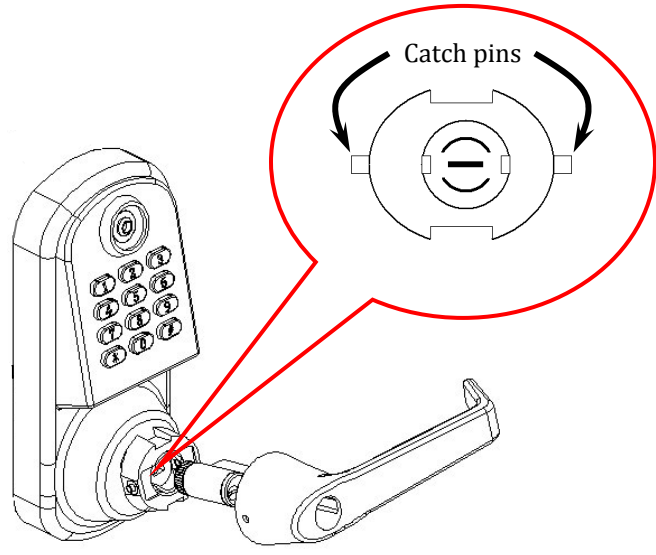

Figure 7

Step 8

Put the strike box in the door frame and the strike plate over it. Fasten with 2 screws. Installation is complete.

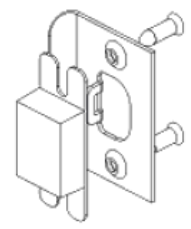
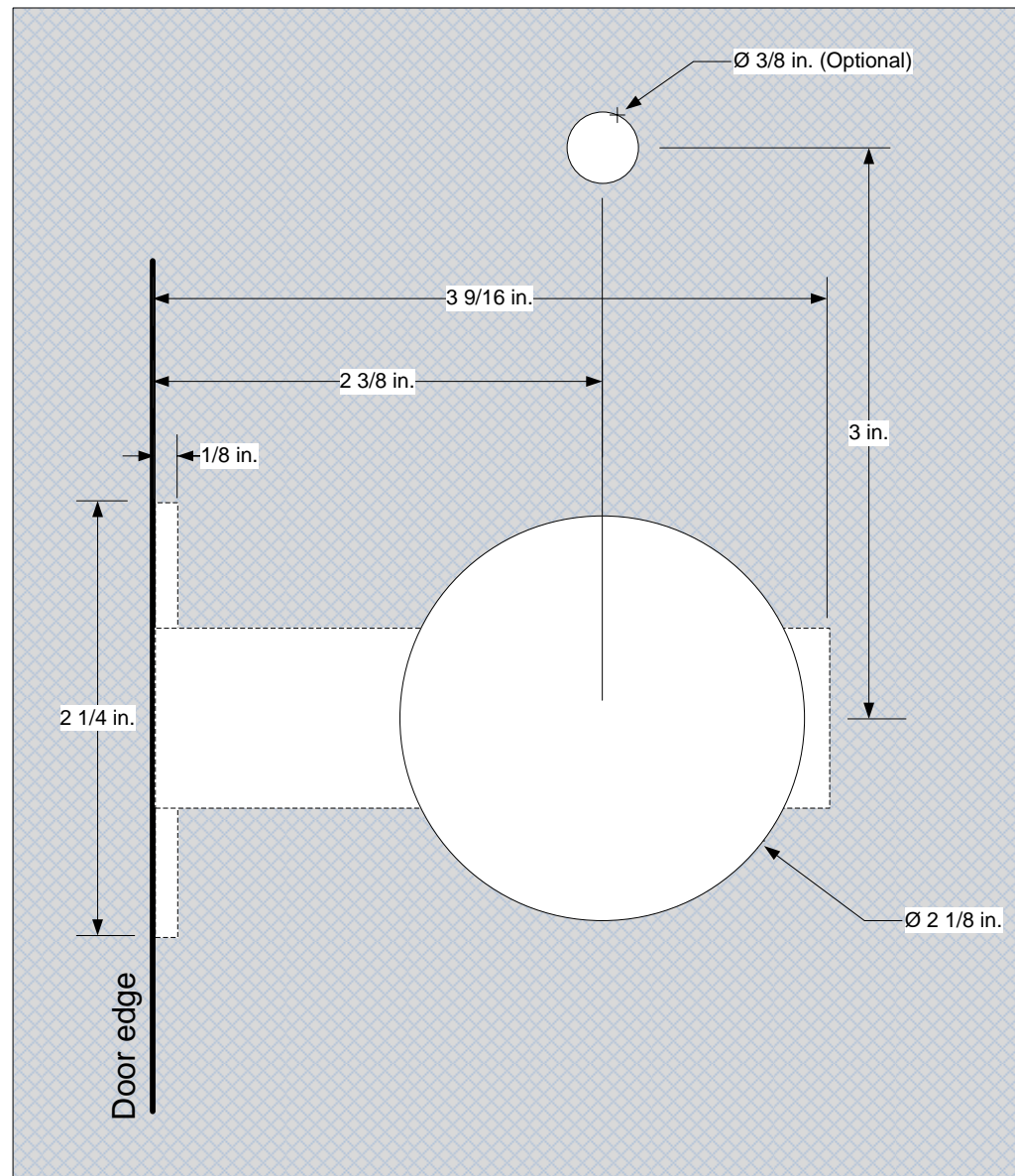
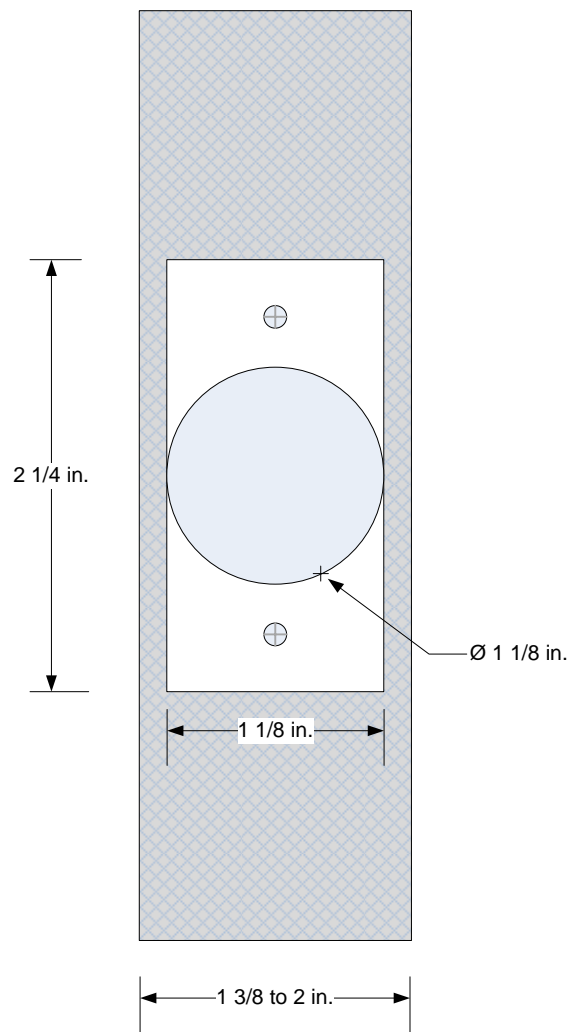

Figure 8

Notes

CrossOver X25 door template – 2³/₈-inch backset

(See page 6 for 2 ³/₄-inch backset and page 7 for door jamb template)



CrossOver X25 door template – 2¾-inch backset

(See next page for door jamb template)

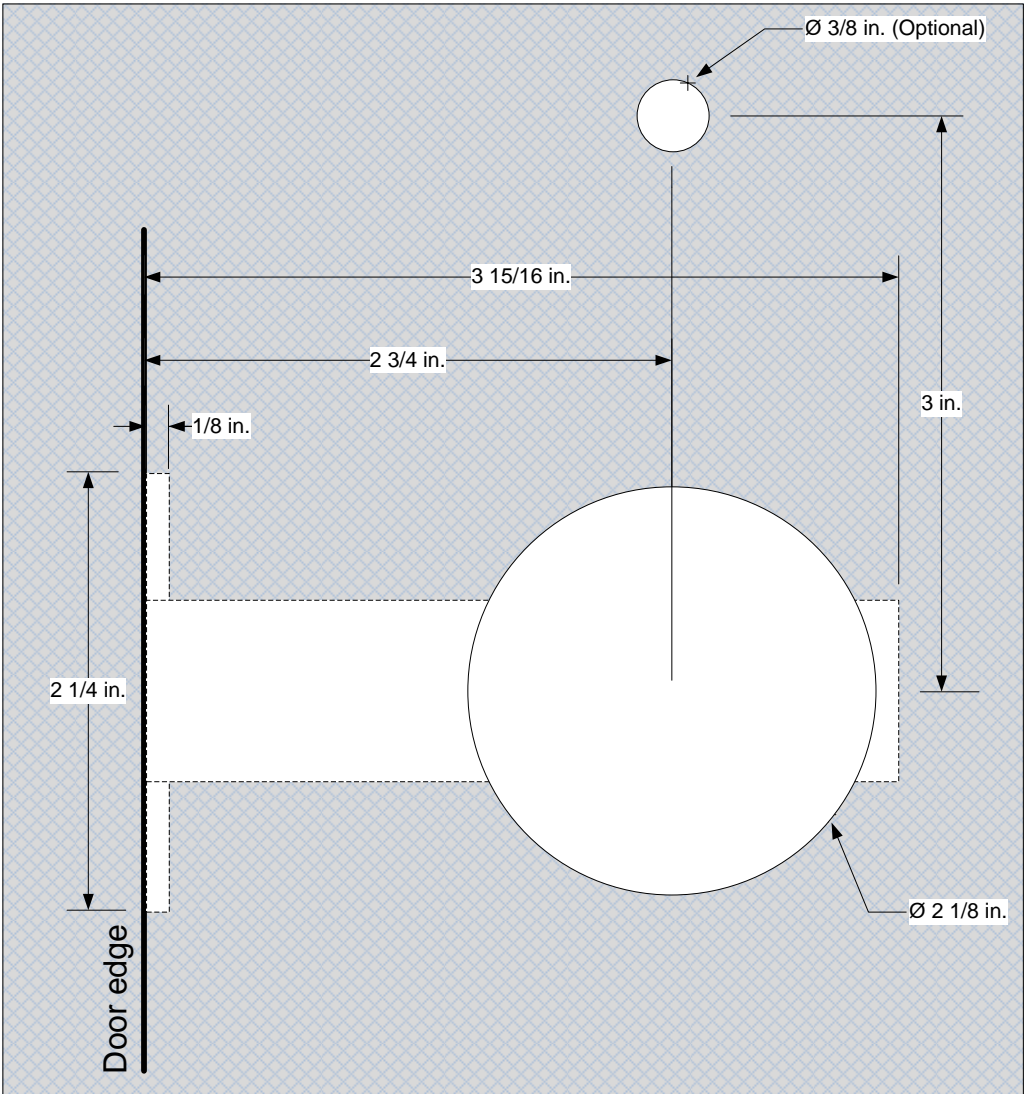
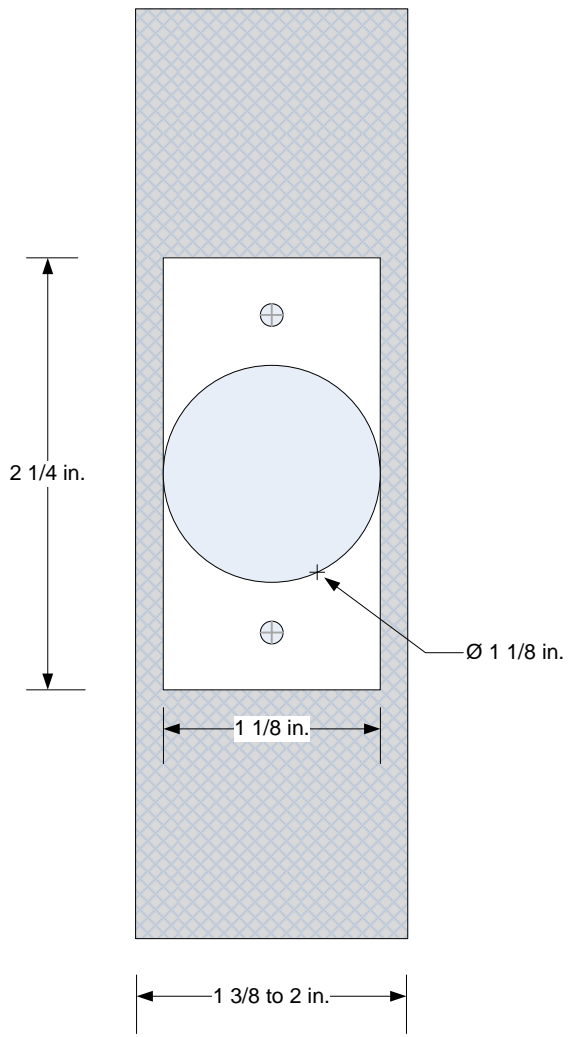

CrossOver X25 door jamb template

(See pages 5 and 6 for door templates)

